



#TeamWilder Toolkit: Wildlife Actions – Building Shelter

One of the best things you can do in your garden or green space is to provide shelter for a variety of species. Shelter is vital for insects, birds, small mammals, amphibians and much more! This toolkit focuses on how you can build shelter to support wildlife.

Contents:

1. Dead wood, log piles & tree stumps
2. Rock or stone pile
3. Nesting boxes for birds
4. Bat boxes
5. Hedgehog house
6. Building a bee or insect home
7. Amphibian or reptile hibernaculum

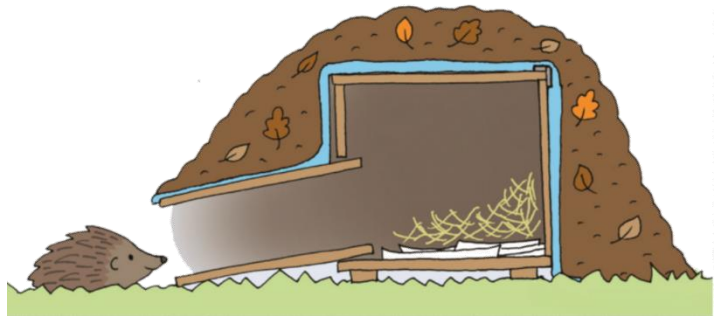

1. Dead wood, log piles & tree stumps

Log piles are perfect hiding places for insects, providing a convenient buffet for frog, birds, and hedgehogs too!

Putting together a log pile will create a village for all things creepy and crawly. In turn, this busy community will attract birds, hedgehogs and frogs looking to snack on a tasty morsel.

A small pile of logs can support a multitude of different insects, provide shelter and food for small mammals, reptiles and amphibians, and a cosy place for wildlife to over-winter or hibernate. Fungi, wood-boring insects, woodlice, beetle grubs and wood wasps all find homes and food in the logs.

These are prey for other animals too: spiders, frogs, toads, hedgehogs, and birds. A simple pile of logs can very quickly become a flourishing wildlife community.

You will need:

Logs! You can get them from tree surgeons or firewood dealers. If you're lucky, some pieces may already contain beetle grubs which could hatch and populate your garden. Native wood is best, but anything will do.



Image credit: Andy Steele



Building your log shelter.

You can build up the logs to form your 'minibeast village' in a variety of ways:

- **Scattered:** Scatter your logs in a flower border or under a hedge. Like this, they are handy for keeping plants apart and mulching the soil, but you'll get more wildlife if you do create a concentrated stack.
- **Neat and tidy pile:** Tidy stacks are often seen in coppiced woodlands. Logs are carefully piled on top of each other, often forming a pyramid.
- **Higgledy-piggledy:** The 'natural' way to do it, and great for architectural impact. But it doesn't create much shade.
- **Organ pipes:** Sunken wood creates the most micro-climate possibilities. If you can't bury your logs, heaped wood chippings are another way to help stag beetles.
- **Giant cheese:** If you can get a real 'wagon wheel' log, it will create the most stable environment of all underneath. Superb for amphibian hibernation.

The five stars of the show...

1. **Devil's coach horse:** Ferocious, predatory beetle that curls its tail up in defence – even at humans! Great for the garden, it eats invertebrates and pests like vine weevil. It can deliver a painful nip, however, so handle with care!
2. **Brown centipede:** Up close, its honey-brown, segmented body hosts just 15 pairs of legs, despite its name! This predatory invertebrate has poisonous claws and large, biting jaws to catch its prey, but is harmless to humans. It may live for four years.
3. **Lesser stag beetle:** Smaller than its famous cousin, it often arrives hidden in firewood logs as a large grub. Save any logs with signs of holes or rot, and adults may emerge in June.
4. **Common toad:** This amphibian may live for up to 10 years if you provide a friendly garden and hefty log pile for it to hibernate in. Likes sparser ponds than frogs and newts.
5. **Common woodlouse:** A familiar minibeast, it is an important recycler of nutrients, feeding on decaying matter. It also provides prey for birds and the specialised woodlouse spider, whose jaws can even pierce human skin!

Rotting wood is also a valuable resource for hundreds of insect species for laying eggs and feeding larvae, so leave some logs lying around your garden amongst your beds or tucked away under shrubs.

2. Rock or stone pile

Create a pile of rocks and stones to provide habitat for insects, small mammals, and amphibians, you can also create a mound of earth to provide a 'beetle bank' – great for beetles to lay their eggs in.



3. Nesting boxes for birds



How to make a nest box



What you need:

- rough cut timber
- some old rubber or a hinge
- 20mm nails
- tools:

cut along dotted line for open fronted robin box

always get an adult to help with tools!

1 Mark out and saw panels
Use diagram above, and write the name of each panel onto the marked out wood.

2 Choose your box type

	hole fronted box: blue tits (25mm) great tits (28mm) sparrows (38mm) starlings (45mm)		open fronted box for robins
--	---	--	-----------------------------

3 Assemble the box
Nail the panels together:

Fix on the roof panel with a hinge or strip of old rubber.

Where to put it:
2-5 metres above the ground, somewhere sheltered.

Illustration: Corinne Welch © Copyright Royal Society of Wildlife Trusts 2015

www.wildlifewatch.org.uk

Making your nest box:

1. Mark out the panels of the future nest box with pencil and a ruler and write the name of each panel onto the marked-out wood.
2. Saw the panels apart. You will need to make a slanted cut between the front panel and roof at a 45-degree angle.
3. Decide which box type you want to make and adjust the front panel accordingly:
 - Hole-fronted tit box – use a hand brace or drill to make a round entrance hole: 25 mm diameter for blue tits; 28 mm diameter for great tits; 38 mm diameter for sparrows.
 - Open fronted robin box – simply saw off 75 mm from the top of the front panel to make a 'window' entrance.
4. Start constructing your box by nailing one of the sides onto the back plate through the back.
5. Nail on the floor (this can be quite tricky – go carefully to avoid splitting the wood).
6. Nail all the other panels into place except for the roof panel.



7. If your carpentry is of a high standard, with evenly proportioned panels and snugly fitting joints, you will need to drill some small holes (1-2 mm diameter) into the floor panel to allow for drainage.
8. Fix on the roof panel with a rubber flap 'hinge' made from scrap rubber. This should cover the join between the roof and back plate completely, so it is waterproof. Nail the rubber into the back plate first, then pull it tightly over the join and nail it onto the roof. The roof should be able to lift away like a lid.
9. After construction, treat the outside of the box only with a water-based wood preservative product, such as 'Cuprinol' or 'Sadolin' (not creosote), to prolong its life and help repel water. If using planed timber, clear polyurethane may be used instead.
10. If you have it, fix a piece of roofing felt to the roof to prolong the life of the box and render it even more waterproof.

Choosing the best location:

Whether fixed to a tree or a wall, the height above ground is not critical to most species of bird as long as the box is clear of inquisitive humans and prowling cats.

If there is no natural shelter, it is best to mount a box facing somewhere between south-east and north to avoid strong direct sunlight and the heaviest rain. The box should be tilted slightly forwards so that the roof may deflect the rain from the entrance.

You can use nails to attach the box directly to a tree trunk or branch; or you can use rope or wire wrapped right around the box and trunk (remembering to protect the trunk from the wire cutting into it by using a piece of rubber underneath it). Both methods are satisfactory, but obviously annual maintenance is easier if the box is wired and can be taken down easily for cleaning.

The number of nest boxes which can be placed in a garden depends on the species you wish to attract.

Many species are fiercely territorial, such as blue tits, and will not tolerate another pair close by; about 2 to 3 pairs per acre is the normal density for blue tits. Other species, such as the tree sparrow, which is a colonial nester, will happily nest side-by-side.

Do not place your nest box close to a bird table or feeding area, as the regular comings and goings of other birds are likely to prevent breeding in the box.

Cleaning your nest boxes:

After the end of each breeding season, all nest boxes should be taken down, old nesting materials removed, and the box should be scalded with boiling water to kill any parasites. Do not use insecticides or flea-powders – boiling water is adequate. Annual cleaning is best carried out in October or November.

Under [the terms of the Wildlife and Countryside Act 1981](#), if unhatched eggs are found in the box, they can only legally be removed from October to January inclusive, and they must be destroyed – it is illegal to keep them.



Building a swift box:

To build a swift box you will need:

- A plank of untreated plywood (1.8m long, 150mm wide and 12mm thick)
- Pencil
- Tape measure
- Saw
- Glue or nails
- hammer
- Drill
- 4 wall plugs and screws
- A suitable location (the eaves of a building)

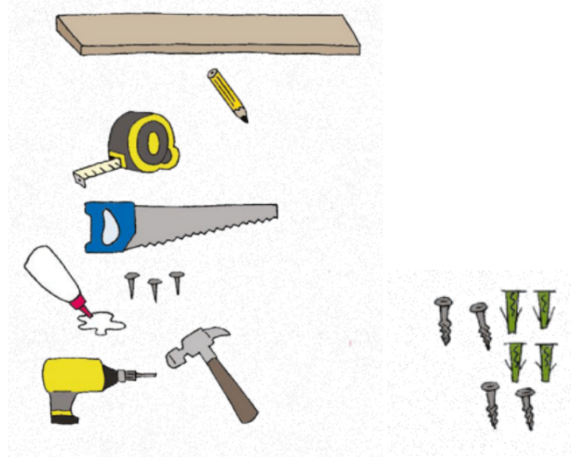

Step 1:

Saw your plywood to these dimensions:

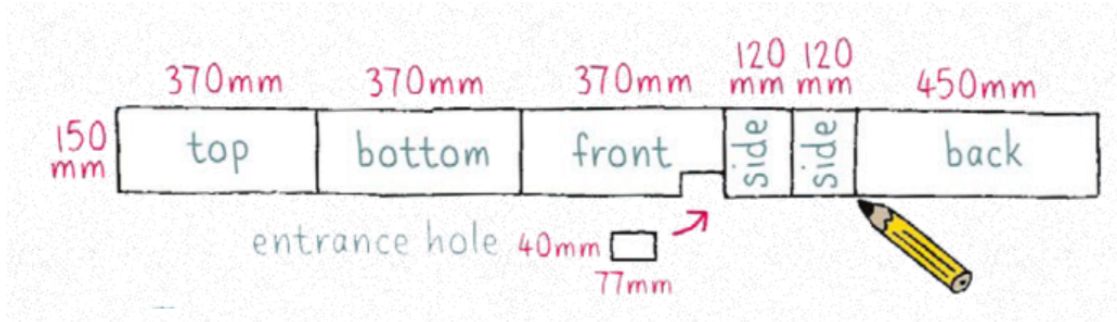

Step 2:

Assemble your swift box using glue or nails.

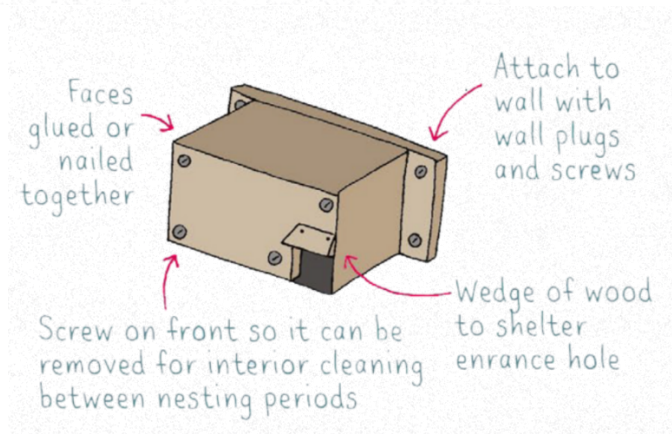

Step 3:

Position your swift box under the eaves of your building on a north/north-east facing wall.

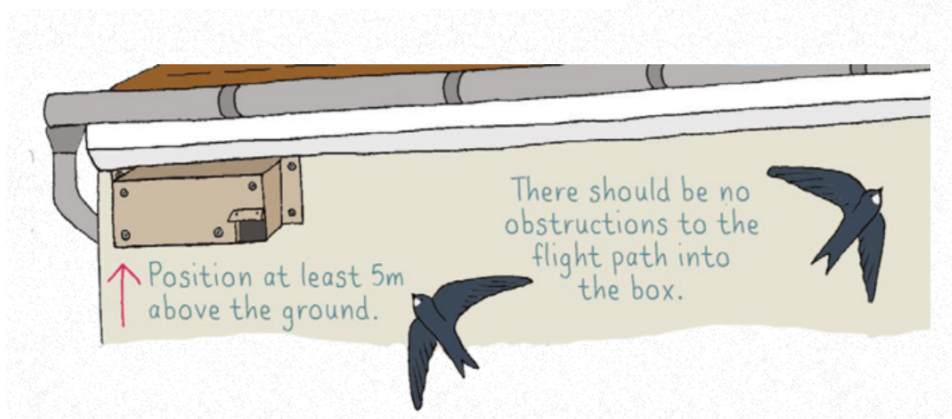

4. Bat boxes

To build a bat box you will need:

- Untreated rough sawn timber
- Tape measure and pencil
- Hammer
- Saw
- Nails
- Brackets

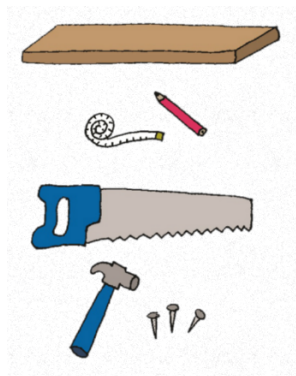

Step 1:

Cut your timber to the dimensions shown below.

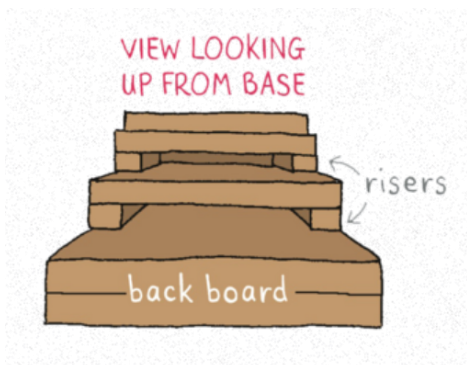
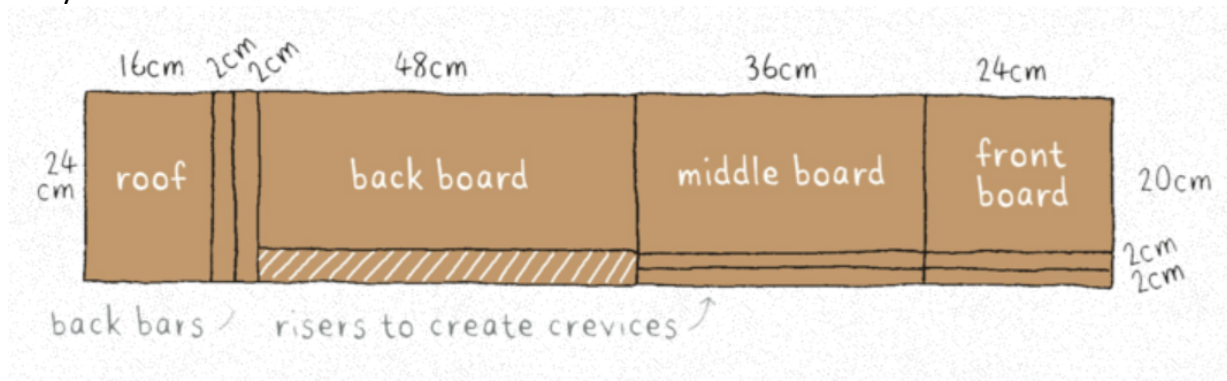

Step 2:

Nail together the boards using the risers to create gaps in between.

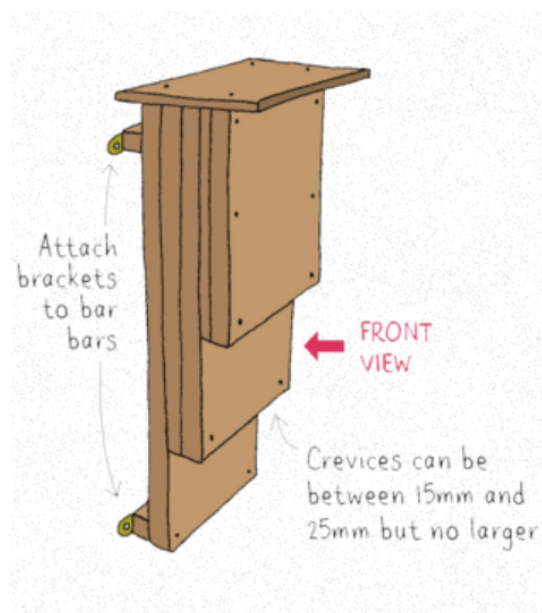

Step 3:

Attach brackets to enable you to attach the box to the wall.

Step 4:

Fix as high as possible in a sheltered, wind-free position, exposed to the sun for part of the day.

Remember!

All UK bats and their roosts are protected by law, which means it is illegal to harm or disturb them. Once up, a bat box cannot be opened legally without a licence. For more information on bats and the law call the Bat Helpline 0345 1300 228.



5. Hedgehog homes

By providing safe places for hedgehogs to live, you're much more likely to see these prickly creatures in your garden.

Sadly, the number of hedgehogs in the UK has plummeted over recent years. While there were estimated to be around 1.5 million in 1995, today there is believed to be less than 500,000.

Hedgehogs need homes just like humans, so making one for them is a great way to encourage them into your garden. Hedgehogs are becoming increasingly reliant on urban and suburban gardens. Urban populations of hedgehogs have increased by up to a third, while rural populations have halved. This decline is likely caused by the loss and degradation of our habitats due to pressures such as development, agricultural intensification, and climate change.

So, whether you live in town or country, you can help to look after garden wildlife like hedgehogs by providing food, water, and shelter.

To build a hedgehog home you will need:

- Hammer and nails
- 2 metal hinges
- Soil
- Straw or dry leaves
- Polythene sheeting
- 20mm untreated FSC plywood boards (birch is ideal!) cut to the sizes shown
- A quiet, shady spot
- Access to your garden for hedgehogs

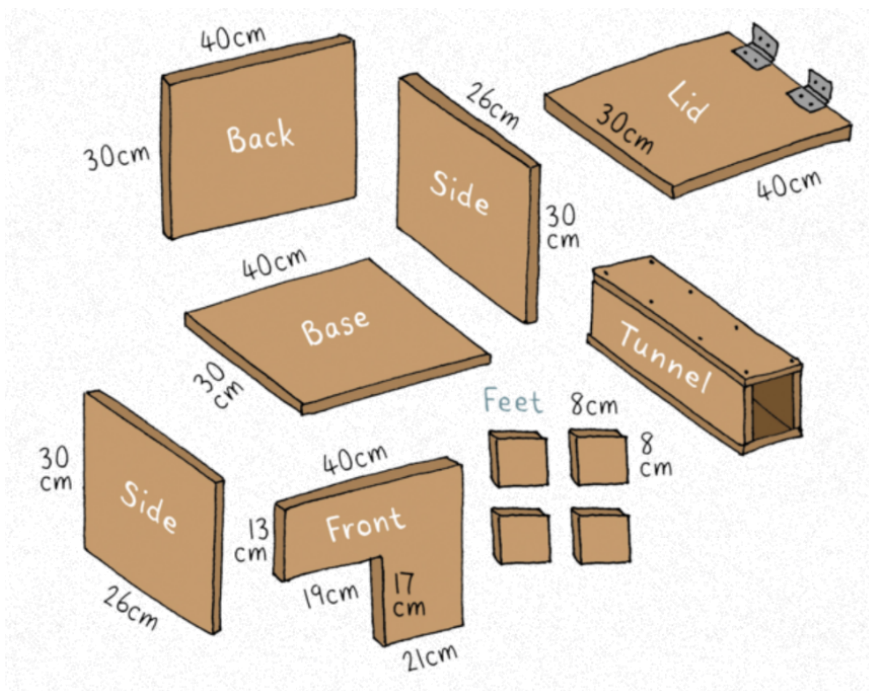
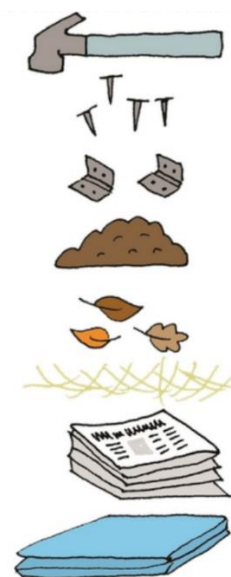

Step 1:

Cut your timber to the dimensions shown.

Credit: Corinne Welch



Step 2:

Assemble the tunnel and main chamber separately; attaching the feet and the hinge flap before putting the box together will make things a little easier.

Don't be tempted to skip the tunnel – it means that predators won't be able to swipe their paws inside! The tunnel will be slightly shorter than the height of the opening so that it can be slotted in at an angle, making a ramp.

You can also drill a hole that will fit a hosepipe into the back of the box to add some extra ventilation.

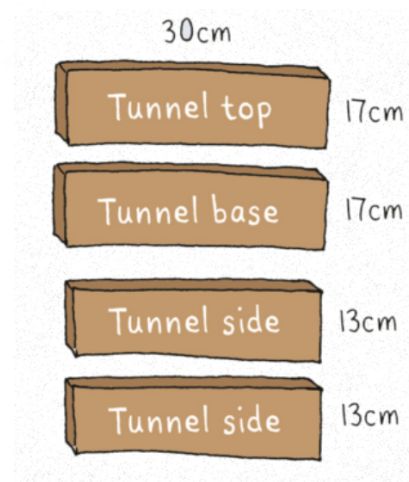

Step 3:

Pick a shady, quiet spot to put your assembled hedgehog house. Lift the lid off the house and put the dry leaves inside.

Step 4:

Cover with polythene sheeting (making sure it's still accessible for cleaning later on), and pack soil and dead leaves around the outside, leaving the entrance and air pipe free of debris.

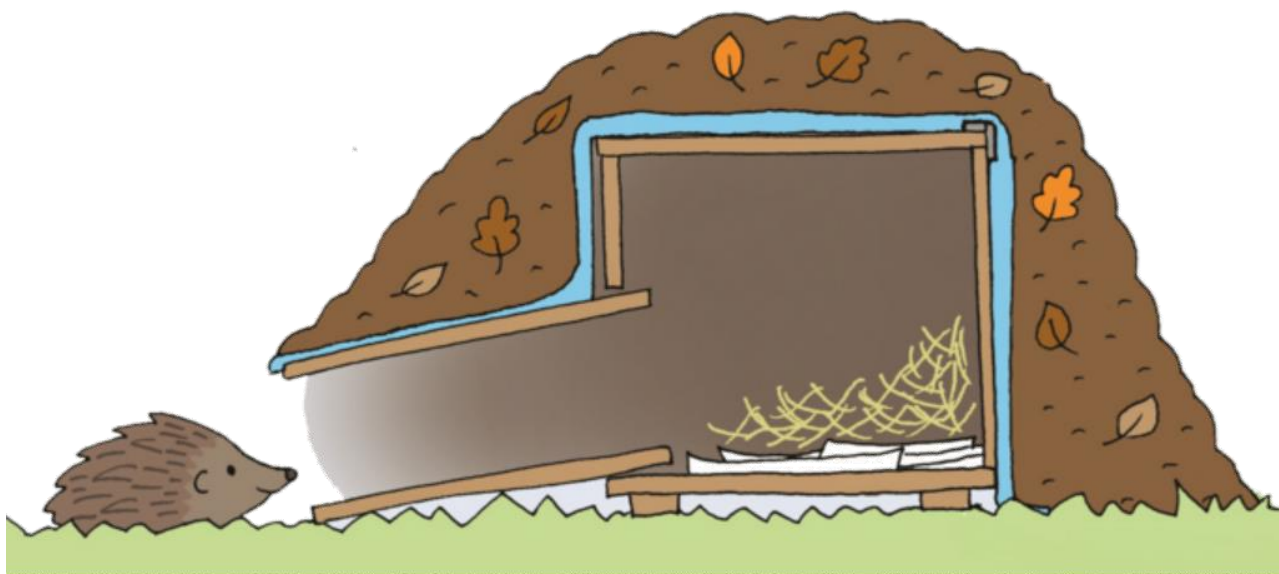

Remember:

Clear out the hedgehog house once a year (late March to early April) to prevent the build-up of pests. Do not clean it out if a hedgehog is in residence though!

Making a log pile or compost heap are also good options for providing space for hedgehogs to nest, and have the added bonus of attracting lots of insects for them to eat.



6. Building a bee or insect home

Unlike the familiar bumblebee and honeybee, most of our bees do not make colonies but are actually solitary. The female spends most of her life searching for suitable nesting sites. Some species will nest in holes in the ground, while others will look for old beetle holes or hollow stems in which to lay their eggs. If you can provide a suitable home, these bees will come to you.

You will need:

- An untreated wooden plank, at least 10 cm wide.
- Plenty of hollow stems of different diameters (including the bees' preferred 3-5 mm), such as bramble, hogweed, reed, or bamboo.
- Saw, drill, screws, and secateurs.
- A mirror fixing to hang the finished nest up.

Building your bee home:

- Cut the plank into four to make a rectangular frame that the stems will sit inside.
- Drill guide holes for the screws (to stop the wood splitting) and assemble the frame.
- Snip your stems into lengths to fit the frame (as wide as the plank), discarding any bent or knobby ones. It's a good idea to include some really big stems (cut with a fine saw), even though they're no use to the bees; they speed up the assembly stage, look attractive and help shelter lacewings and ladybirds over winter.
- Lay your frame on a tilted surface and carefully pack it with stems. Only as you add the final few does the whole thing suddenly lock solid.
- Finally add a backing board to the bee home.

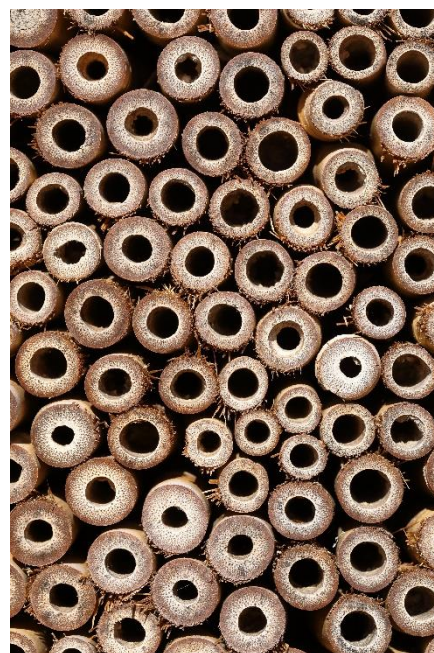

Image credit: Martin Woortman

Hanging your bee home:

Hang your hotel on a sunny wall, sheltered from rain. Remember to clean your hotel once a year to remove any build-up of fungi, debris, and parasites.

What happens next?

Watch as solitary bees, like the [red mason bee](#), investigate your finished bee hotel in the spring. With any luck, the females will lay their eggs inside the stems of your hotel. Each egg is left with a store of pollen for the grub to eat when it hatches. The egg is sealed up behind a plug of mud, in a 'cell'. One stem may end up with several 'cells' in it. The young bees will emerge the following year.

Another way to create a bee home:

Alternatively, you can use a piece of wood at least 75mm thick, an electric drill and drill bits in a range of diameters from 3mm to 10mm to drill into the wood to create a similar effect.

- Make sure you are drilling in a safe place and that the wood is secure.
- Drill randomly placed holes into one side of the wood, as deep as you can, but making sure not to go right through.
- Different species will prefer different sized holes - the 10mm holes are preferred by the **Red Mason Bee** (*Osmia bicornis*). The 3mm holes are preferred by the **Large Headed Resin**



Bee (*Heriades truncorum*) that plugs the hole with tree resin then armour plates it with grains of sand.

- Ensure the holes are free from any rough edges that might obscure the hole.
- Then position the wood somewhere south facing in full sun.

7. Amphibian or reptile hibernaculum

Hibernacula are underground chambers that amphibians and reptiles use throughout the winter to protect themselves from the cold.

Amphibians and reptiles like frogs, toads, newts, lizards, and snakes are regular visitors to gardens, especially those with log piles, sunny spots, ponds, bogs and compost heaps. Creating a hibernaculum in your own garden will provide a safe space for amphibians and reptiles to hibernate over winter.

How to make a hibernaculum:

- In a sunny spot, dig a hole about 50cm deep and 1.5 metres across.
- Fill with logs, branches, bricks, and rocks, leaving plenty of gaps in between.
- Insert entrance tubes (drainpipes) at ground level into the hole.
- Cover the pile with soil (to about 50cm high).
- Plant meadow seeds or long grasses over the mound to create a feast for summer pollinators.

Build a hibernaculum

Great for amphibians and reptiles!



You will need:

- Spade
- Logs and branches
- Rocks and bricks
- 2-3 drainpipe off-cuts or cement pipes
- Turf or meadow flower seeds (optional)

If using plastic drainpipes, roughen the insides with sandpaper so that they are not too slippery for animals to climb

- 1 In a sunny spot, dig a hole about 50cm deep and 1.5 metres across. Be careful not to build your hibernaculum on free-draining sites or where the soil gets waterlogged.
- 2 Fill with logs, branches, bricks and rocks, leaving plenty of gaps in between.
- 3 Insert entrance tubes (drainpipes) at ground level into the pile.
- 4 Cover the pile with soil (to about 50cm high).
- 5 You can plant meadow seeds or turf over the mound.

Illustration: Lorraine Welch © Copyright: Royal Society of Wildlife Trusts 2015

www.wildlifewatch.org.uk

This toolkit has been created with credit to The Wildlife Trusts.

